

12 SUB

12-INCH SUBWOOFER

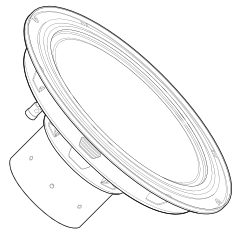

RAVEN
DESIGN STUDIO



KEY FEATURES

DESIGN GOALS

The primary design goal was to allow the deepest reach and the lowest distortion for best bass in the smallest possible sealed enclosure. The overall depth of the driver was configured in order to fit under seat enclosures.

RIGID INVERTED DOME

The extremely rigid inverted cone/dome is made of carbon fiber and fiberglass with high mass to achieve a low resonance frequency in a small enclosure. To assure the integrity of the cone/dome under high pressure of deep X_{max} in a very small enclosure, the absolute best answer was carbon fibers flattened to extreme thinness and interwoven in the Raven signature line checkerboard pattern.

SURROUND AND SPIDER

The three roll rubber surround and spider are FEA optimized for maximum excursion and minimum distortion in this specific application.

ORIGINAL MOTOR STRUCTURE

The proprietary FEA optimized original motor structure is designed to be continuously linear. Magnetic flux in the gap is constant and symmetric. The inductance is minimized and symmetric over its range. The magnet is also designed for optimized voice coil cooling to withstand high power and high excursion.

MOUNTING DEPTH

The Raven 12 Sub mounting depth is only 136 mm (5.354 in) with no rear vents so that the enclosure can be as shallow and compact as possible, even allowing contact inside the enclosure between the rear of the magnet and the back wall.

VERSATILITY AND DURABILITY

All metal surfaces have a special multi coats treatment for salt water protection. While we do not claim "marine grade", all Raven Design Studio speakers and drivers are designed, engineered and finished to withstand any environment. They can safely be used in cars, bikes, boats, ATVs, planes, homes. All seasons. All terrains. We consider this a minimum requirement.

OPTIONAL GRILLE

Compatible grilles available separately for purchase.



12 SUB

12-INCH SUBWOOFER

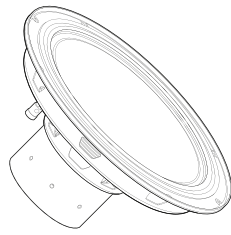

RAVEN
DESIGN STUDIO

TECHNICAL DATA

RECOMMENDED XOVER POINT	75 Hz - 1000 Hz
RECOMMENDED XOVER SLOPE	12 dB/oct or higher
ALTERNATIVE XOVER SLOPE	18 dB/oct , 24 dB/oct
NOMINAL POWER HANDLING	600 W
PEAK POWER	1200 W
SENSITIVITY 2.83 V / M	88 dB
EFFICIENCY 1 W / 1 M / 2 OHM	81 dB
NOMINAL IMPEDANCE	2 Ohm
DC RESISTANCE	1.7 Ohm
VOICE COIL DIAMETER	76 mm (3 inch)
FORMER MATERIAL	Aluminum
VOICE COIL WIRE	Copper
VOICE COIL WINDING	4 layers single voice coil
INDUCTANCE AT 1 KHZ	0.25 mH
SURROUND	3 rolls SBR rubber, FEA optimized for very small enclosures.
CONE MATERIAL	Proprietary layered carbon / black fiberglass, profile and composition FEA optimized.
MAGNET	High power Neodymium optimized by FEA modeling
NET TOTAL WEIGHT	5 kg (11 Lb)

THIELE-SMALL PARAMETERS

IMPEDANCE	2 Ohm single voice coil	LE	0.25 mH at 1 kHz
RE	1.7 Ohm	BL	11 N/A
FS	29.7 Hz	MMS	354 grams
QTS	0.74	CMS	0.08 mm/N
QMS	3.61	XMAX	+/- 20 mm
QES	0.93	SPEAKER VOLUME	1.7 L (0.06 CuFt)
VAS	29.64 L (1.05 CuFt)	DISPLACEMENT	
SD	510.7 cm ²		

ENCLOSURE SPECIFICATIONS

SEALED ENCLOSURE:	
MINIMUM	17 L (0.6 CuFt) , -3 dB at 40 Hz
BEST	21 L (0.75 CuFt) , -3 dB at 38 Hz
POWER TO REACH +/- 20 MM XMAX	940 watts
VENTED ENCLOSURE:	
OPTIMUM	56 L (2.0 CuFt) -3 dB at 25 Hz
PORT TUNING	25 Hz
PORT DIAMETER	101.6mm (4.0 in) diameter
PORT LENGTH	584mm (23 in)
RECOMMENDED	High Pass filter: 20 Hz @ 12 dB/oct
MAXIMUM POWER	1300 watts into 2 ohms

FACE

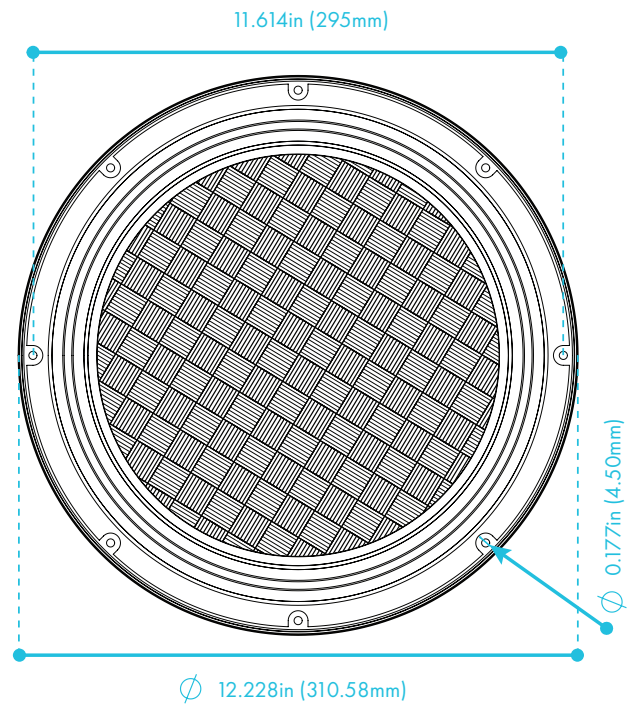

SIDE PROFILE

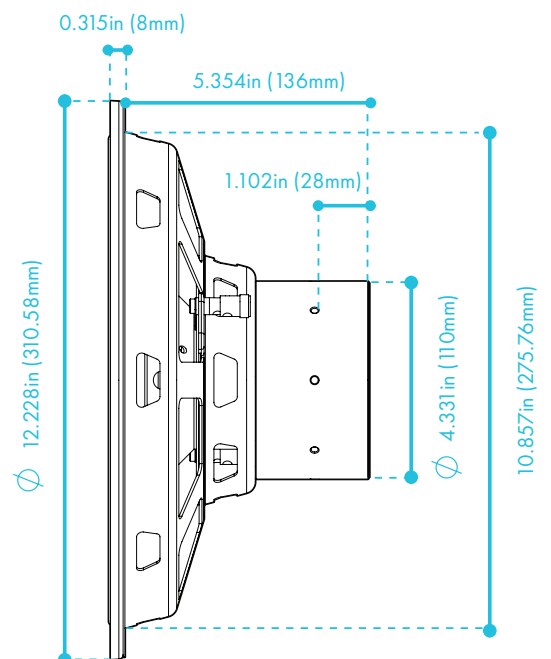

12 SUB

12-INCH SUBWOOFER

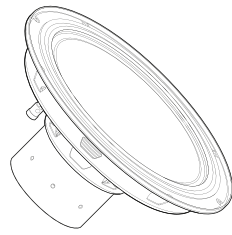

SEALED ENCLOSURE (BEST)

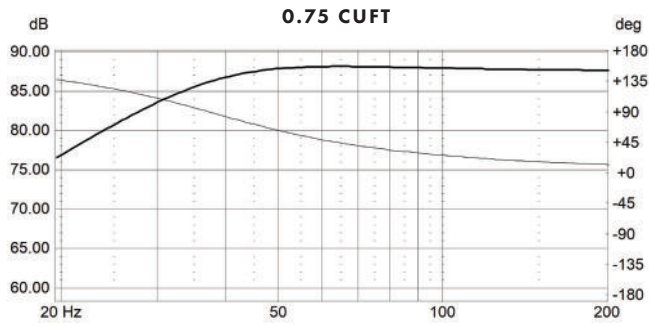

SEALED ENCLOSURE (MINIMUM)

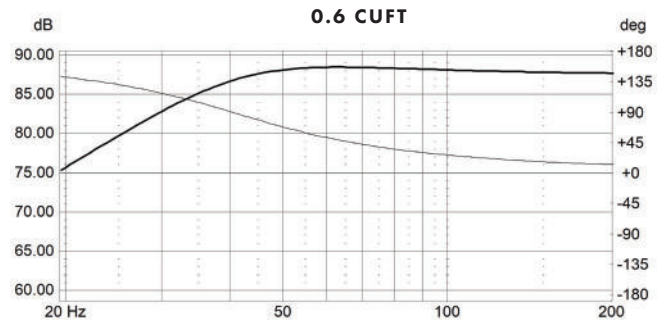

VENTED ENCLOSURE

2.0 CUFT - 25 HZ PORT

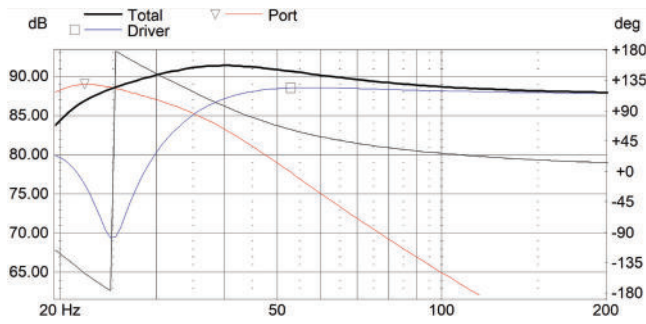

THD VS EXCURSION

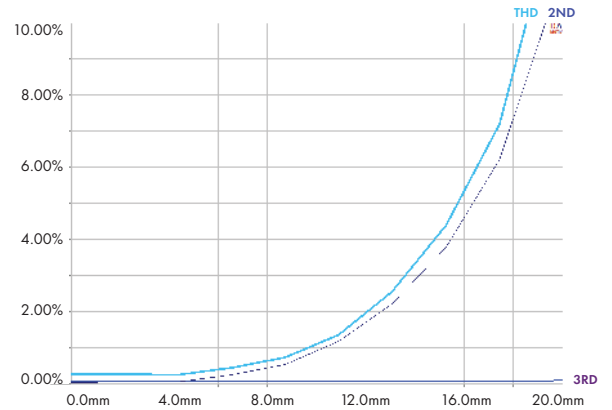

BL VS EXCURSION

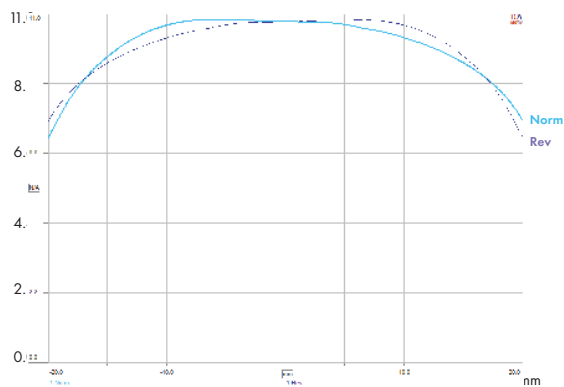

INDUCTANCE VS FREQUENCY VS EXCURSION

